

I-GS-V16/V8

COSMO ELECTRONICS CO.,LTD
<http://www.csm-e.co.jp/>



4K-2K High Resolution LCD Panel Inspection Tester



■4K 2K 高解像度 パネル検査対応

UrtraHD 4K 2K Panel inspection available

■V BY ONE HS 16Lane 標準対応*

V By One HS 16 Lane standerd i-GS-V8 : 8Lane

■PC-USB接続でリモート操作可能

Remote controled by PC using USB connection
最大4台同時操作対応 Maximum 4 set

■スタンドアローン操作対応

PC less operation available

■省スペース設計

Small Size

V-By-One Signal Generator Specification

V-BY-ONE OUT	8lane (4k2k 60Hz)/16lane(4k2k 120Hz)
Pattern Size	MAX 4096 × 4096
Color Depth	MAX R/G/B 10bit
Bitmap	MAX 4bitmap (Max Size 4096 × 2048) * PC connection needed
Data Transfer Clock	MAX 85MHz
Basic Pattern	30 (H/W Generation Pattern)
Lane Arrange	2mode 8Lane / 1Mode 16 Lane
USB port	1PORT (USB 2.0 Support)
I2C	1PORT
I/O	10 Signal
Operation Temperature	10°C ~ 40°C
Operation Humidity	85% Max (Without water ball)
Input Power Supply	AC100V~240V 50/60Hz
Box size	350 × 100 × 165(mm) (W × H × D)

Test Pattern example

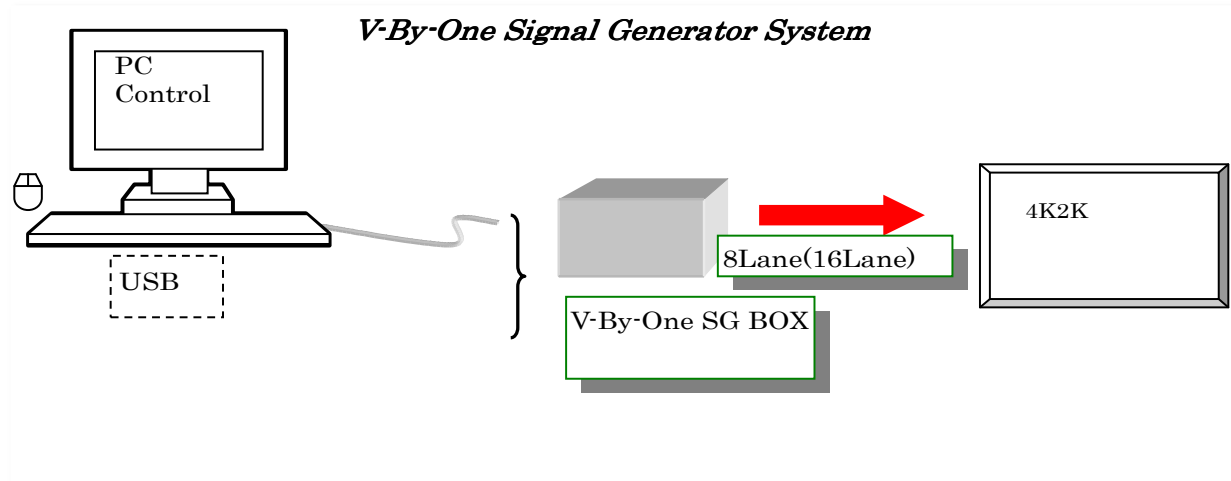
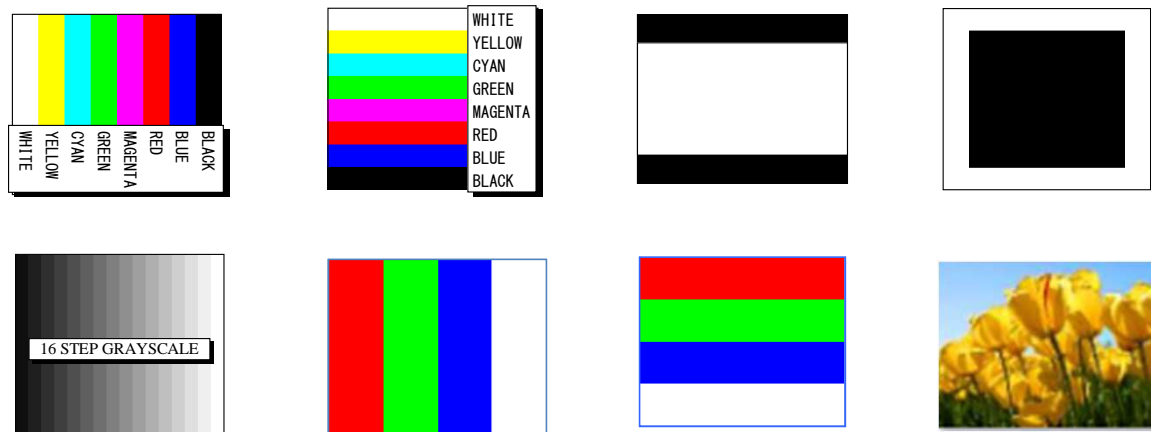

<http://www.csm-e.co.jp/>

コスモ電子株式会社
三重県四日市市宝町1番地
TEL 059-349-1123 FAX 059-349-1143

COSMO Electronics CO.,LTD
1-Takaramachi Yokkaichi City Mie Japan
TEL +81-593-49-1123 FAX +81-593-49-1143